

### DK-35041/3-A-F - Aerial Installation Cable

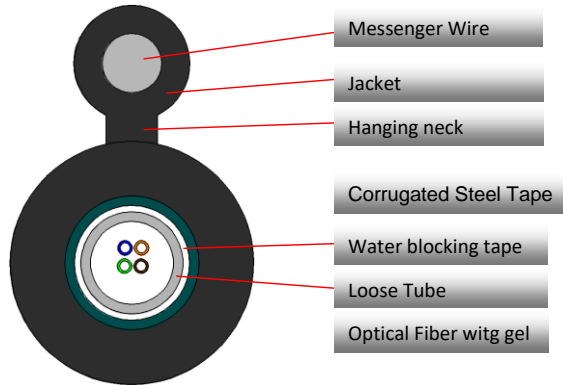

#### Abstract

Loose tube cable is a design that has high tensile strength and flexibility in a compact cable size. Our loose tube cable provides excellent optical transmission and physical performance.

#### SCOPE

This specification covers the design requirements and performance standard for the supply of optical fiber cable.

This specification covers the general requirements and performance of cable which

We offered including optical characteristics, mechanical characteristics and geometrical characteristics.

The cable which we offered are designed, manufactured and tested according to international standards as follows:

IEC 60794-1-1	Optical fiber cables. Part 1: Generic specification
IEC 60794-1-2	Generic specification- basic optical cable test procedures
IEC 60793-3	Outer cables- sectional specification
IEC 60794-3-20	Outdoor cables-family specification for optical self-supporting aerial telecommunication cables
EIA/TIA 598 B	Color code of fiber optic cables
ITU-T G.650	Definition and test methods for the relevant parameters of single-mode fibers
ITU-T G.652	Characteristics of a single-mode optical fiber cable
ITU-T G.655	Characteristics of a non-zero dispersion-shifted single-mode optical fiber and cable

#### Technical Features

The optical fiber is made of high pure silica and germanium doped silica. UV curable acrylate material is applied over fiber cladding as optical fiber primary protective coating. The detail data of optical fiber performance are shown in the following table



The optical fiber is made of high pure silica and germanium doped silica. UV curable acrylate material is applied over fiber cladding as optical fiber primary protective coating. The detail data of optical fiber performance are shown in the following table.

OM2 fiber use special spun device successfully controlled the value of PMD, and make sure that it keeps stable in cabling.

Approved by optical communication products ministry of quality supervision and inspection center, the connection between OFS fiber in and outside is good .The single-end connect-loss won't be over 0.1 dB and the double-end connect-loss is all little than 0.05dB.

Apply to non-relay communication network. Features: proof test >1%.

**OM2 In cable**

No.	Items		unit	Specification
				OM2
1	Core Diameter		μm	50±2.5
2	Cladding Diameter		μm	124.8±1.0
3	Cladding Non-Circularity		%	≤1.0
4	Core-Cladding Concentricity Error		μm	≤1.5
5	Coating Diameter		μm	245±7
6	Coating Non-Circularity		%	≤6.0
7	Cladding-Coating Concentricity Error		μm	≤12.0
8	Bandwidth (min)	850nm	MHz·km	200
		1300nm	MHz·km	600
9	Attenuation Coefficient	850nm	dB/km	≤2.7
		1300nm	dB/km	≤0.6



## Dimension and Properties

General properties	Unit	Nominal value
Fiber count ( <b>OM2</b> )	PC	4
Messenger wire	material	Steel wire
	OD	1*1.4mm
Loose Tube	material	PBT White
	OD	2.15±0.1mm
Corrugated steel tape thickness	mm	0.18
Outer sheath	material	LSZH
Cable OD	mm	7.2*12.2
Max. allowable pulling force	N	1000/2500
Crush resistance	N/100mm	300/1000
Flame resistance		CPR Dca

Working conditions		
Temperature range	Transport and storage:- 40°C to +70°C	Min Bending Radius
	Installation:-40°C to +60°C	Installation:20 x OD
	Operation:-40°C to +70°C	Operation:10 x OD

- Note: 1. the nominal outer diameter may vary by ± 5%.  
 2. The nominal cable weight may vary by ±10%.  
 3. The nominal cable length each drum may vary by ±10%.

### FIBERS AND TUBE COLOR CODE SCHEME: according to EIA/TIA 598B

Fiber color	Blue	Orange	Green	Brown
Tube color	White			

### TEST REQUIREMENTS

The cable is in accordance with applicable standard of cable and requirement of customer.

The following test items are carried out according to corresponding reference.

No	Item	Reference
Tests of Optical Fiber		
1	Attenuation coefficient	IEC 60793-1-40
2	Chromatic dispersion	IEC 60793-1-42
3	Mode field diameter	IEC 60793-1-45
4	Cladding diameter	IEC 60793-1-20

5	Cladding non-circularity	IEC 60793-1-20
6	Core/clad concentricity error	IEC 60793-1-20
7	Cable cutoff wavelength	IEC 60793-1-44

<b>Tests of Outdoor cable (After cabling)</b>			
1	Tensile Test	IEC-60794-1-E1	-Max. allowable pulling force: installation tensile; sample length: no less than 50 meters, time: 10 minutes; -Fiber strain at max. load : max. 0.33 %. -No damage to the outer jacket and inner elements. Reversible.
2	Crush test	IEC-60794-1-E3	-Load:short time crush strength, time: 5 minutes, length: 100 mm, number of tests: 3; -No damage to the outer jacket and inner elements. Reversible.
3	Impact test	IEC-60794-1-E4	-Impact energy: 3J , radius: 10.0 mm, impact points: 3 Number of impacts: 1 -No breakage of the optical fiber, -No splits or cracks in the outer jacket. -Attenuation increase $\leq 0.1$ dB, reversible
4	Repeated bending test	IEC-60794-1-E6	-1m cable length, bending radius: 20 times cable's diameter. 25 cycles, duration of cycle: 2s. -No damage to the outer jacket and inner elements. Reversible
5	Torsion test	IEC-60794-1-E7	-2m cable length, $\pm 180$ degrees, 5cycles; -no damage to the outer jacket -Attenuation increase $\leq 0.1$ dB, reversible
6	Bending test	IEC-60794-1-E11	- Diameter of mandrel: 20xD ,number of turns/helix: 4 number of cycles: 3 , -No damage to the outer jacket and inner elements (20 oC). reversible
7	Temperature cycling test	IEC-60794-1-F1	-Temperature step: +20oC $\rightarrow$ -40oC $\rightarrow$ +70oC $\rightarrow$ -40oC $\rightarrow$ +70oC $\rightarrow$ +20oC, time per each step: 12 hrs, -number of cycles: 2 cycles -they shall be no change in attenuation variation for reference value (the attenuation to be measured before test at +20 $\pm$ 3 oC) - reversible
8	Water penetration test	IEC-60794-1-F5	-Water height: 1m, sample length: 3m, duration of test: 24 hrs. - No water leakage at the end of the sample
9	Drip test	IEC-60794-1-E14	-Three 0.3m samples suspended vertically in a climate chamber, raised temperature to +70°C. -no filling compound shall drip from tubes after 24 hr

**PACKING AND DRUM**

Our cables are packed in wooden axles, coiled on Bakelite & wooden reel. During transportation, right tool should be used to avoid damaging the package, and handle carefully. Cables should be protected from moisture; Cables should be kept away from high temperature condition and spark; Cables should be protected from over bending and crushing; Cables should be protected from mechanical damage.

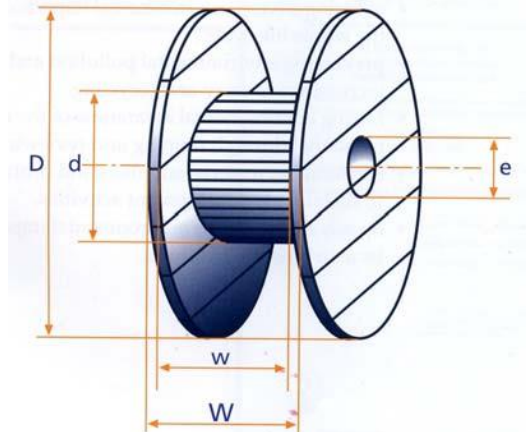

- 5.2 The color of marking is white. ( At every meter, the outer sheath of the fiber cable shall be printed )  
Outer sheath making legend can be changed according to user's requests.
- 5.3 Outdoor cable packing.  
Bakelite & wooden drum.  
Strong wooden batten protection.